

# CF-Series

The most sold model of auto case former. Its performance is proven in various business field from pharmaceutical to food production.

## CF-101

Decisive model of auto case former flexible to various needs.



### High functionality and space saving design

Carton sheet extraction section is driven by servo motor and it improve precision of carton unfolding. A swing taping unit simplifies tape exchange process.



### Easy size change

Digital indicator makes it possible to simplify size change and to ensure reliable reproductivity. Carton loading work becomes less fatigue by locating carton magazine at lower position.

# CF-101

High performance and precision of carton forming enhance productivity of a production line.

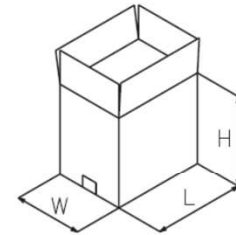
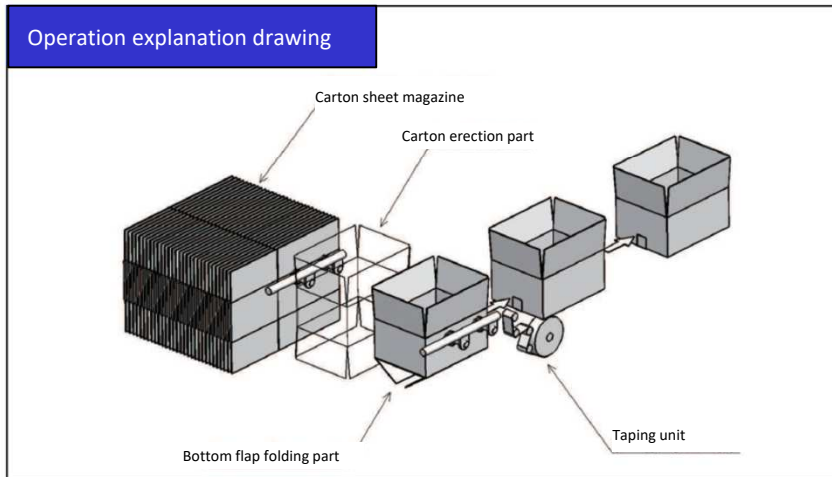

CF-101			
	L	W	H
min	240	180	80
max	500	300	400

Specification	
Model	CF-101
Capacity	13cpm(MAX) (MAX20cpm for CF-101H)
Electric Power	3 Phase 200V 400W
Compressed Air	0.49MPa 200Nℓ/min
Carton Type	Carton A type left open type
Carton magazine	Approx. 80 pcs. accommodation (A/F type carton)
Carton unfolding part	Vacuum type
Sealing part	Taping unit Kraft or OPP tape
Carton transport part	Side belt conveyor
Size change	Steering wheel adjustment (with digital indicator)
Safety Cover	PET full guard cover (with safety switch)
Machine Size	L=2000mm W=1785mm H=1670mm
Pass Line	600 mm
Machine Weight	Approx. 450kg

Options	
<input type="checkbox"/>	Large capacity sheet stock magazine
<input type="checkbox"/>	Hot melt sealing type
<input type="checkbox"/>	Adhesive tape with water application
<input type="checkbox"/>	Special carton size
<input type="checkbox"/>	Carton right open type
<input type="checkbox"/>	Various stamping devices
<input type="checkbox"/>	Others

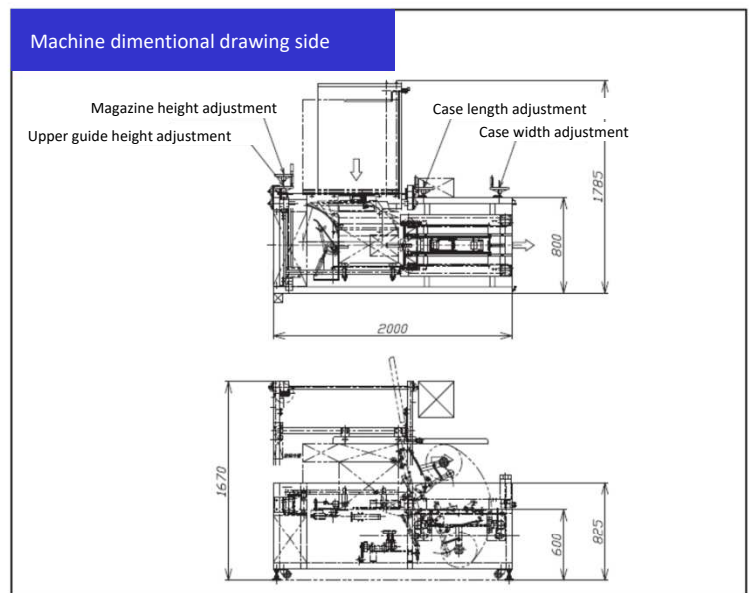

1-19-7, Yokoe, Ibaraki-shi, Osaka, Japan 567-0865

TEL: +81-72-637-3420 FAX: +81-72-637-3464  
E-mail: info@yeg.co.jp URL: <http://www.yuhara-engineering.com>

Business Item ● Cartoning Machine(Horizontal · Vertical) ● Packing Machine ● Carton caser ● Robot caser ● Wrap-around caser  
● Case former · Case sealer ● Palletizer ● Auto feeder ● Cost-saving · factory automation facility