

Under open frame structure greatly enhances cleanliness and maintainability and keeps clean environment.

## CF-102

Auto case former considerate of environment and corresponding to new generation



### Clean Environment

Under open frame structure and dust pan for paper dust collection enhances cleanliness and maintainability.

### Easy size change

A swing taping unit simplifies tape exchange process.

### Reducing Work load

Carton loading work becomes less fatigue by locating carton magazine at lower position.

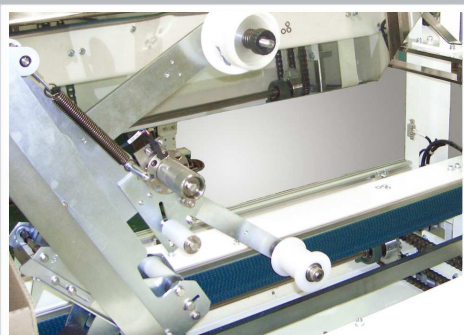

# CF-102

High performance and precision of carton forming enhance productivity of a production line.

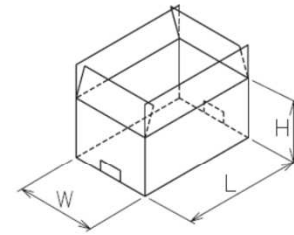
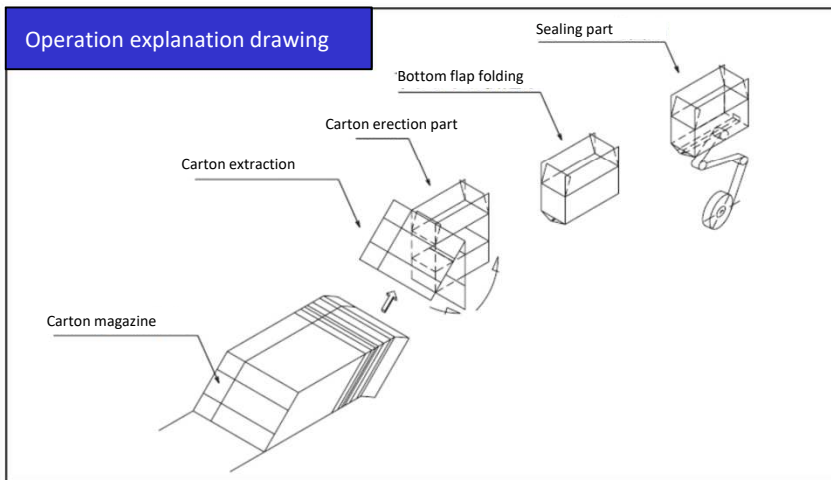

CF-102			
	L	W	H
min	300	200	100
max	400	250	150

Specification	
Model	CF-102
Capacity	20cpm
Electric Power	3 Phase 200V 800W
Compressed Air	0.49MPa 300Nℓ/min
Carton Type	Carton A type left open type
Carton magazine	Approx. 100 pcs. accommodation (K-6 type carton)
Carton unfolding part	Vacuum type
Sealing part	Taping unit Kraft or OPP tape
Carton transport part	Side belt conveyor
Size change	Steering wheel adjustment (with digital indicator)
Safety Cover	PET full guard cover (with safety switch)
Machine Size	L=3290mm W=1060mm H=1976mm
Pass Line	900 mm
Machine Weight	Approx. 600kg

Options	
<input type="checkbox"/>	Large capacity sheet stock magazine
<input type="checkbox"/>	Hot melt sealing type
<input type="checkbox"/>	Gummed tape with water application
<input type="checkbox"/>	Special carton size
<input type="checkbox"/>	Carton right open type
<input type="checkbox"/>	Various stamping devices
<input type="checkbox"/>	Others

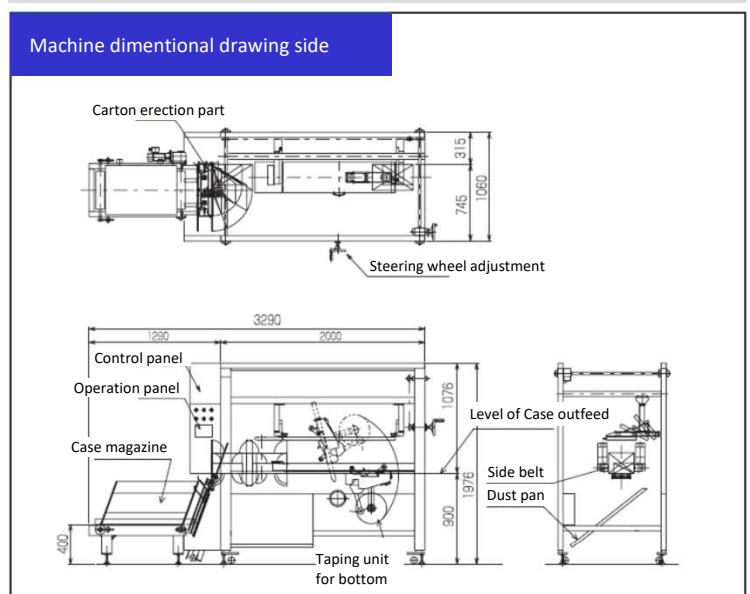

1-19-7, Yokoe, Ibaraki-shi, Osaka, Japan 567-0865

TEL: +81-72-637-3420 FAX: +81-72-637-3464

E-mail: info@yeg.co.jp URL: <http://www.yuhara-engineering.com>

Business Item ● Cartoning Machine(Horizontal · Vertical) ● Packing Machine ● Carton caser ● Robot caser ● Wrap-around caser  
● Case former · Case sealer ● Palletizer ● Auto feeder ● Cost-saving · factory automation facility