

UC-Series

Under open frame structure greatly enhances cleanliness and maintainability and keeps clean environment. Compact and space saving design is suitable to various needs.

UC-102

Auto Case Sealer considerate of environment corresponding to new generation

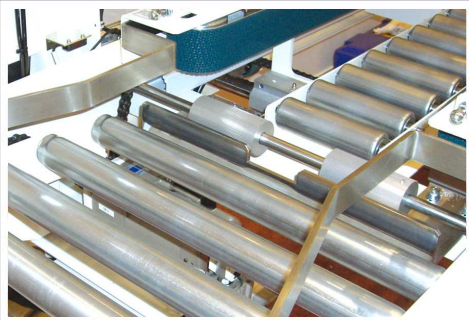

High Maintainability

Under open frame structure improve cleanliness, maintainability.

Reliability from achievement

Reliability of the taping unit is proven by our achievement.

High Safety

The safety cover is made of PET with safety switch.

UC-102

Simple and high performance enhance productivity of production line.

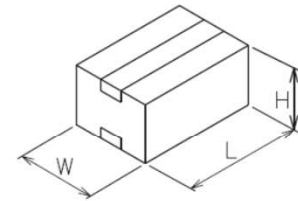
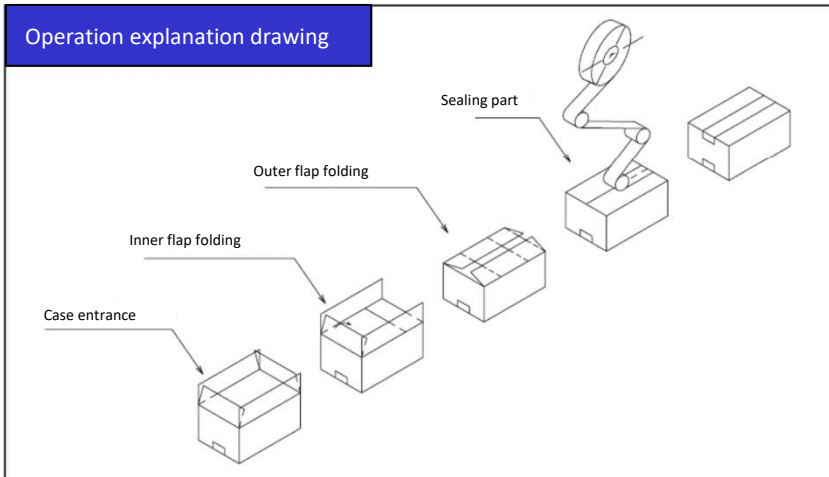

UC-102			
	L	W	H
min	240	150	100
max	500	400	400

Specification	
Model	UC-102
Capacity	20cpm
Electric Power	3 Phase 200V 300W
Compressed Air	0.49MPa 100Nℓ/min
Carton sealing part	Taping unit
Carton transport part	Kraft or OPP tape
Sealing method	Side belt conveyor
Size change	Steering wheel adjustment (2 locations) (with digital indicator)
Safety cover	PET full guard cover (with safety switch)
Machine Size	L=2680mm W=1200mm H=1570mm
Pass Line	600 mm
Machine Weight	Approx. 500kg

Options	
<input type="checkbox"/>	Top and bottom tape sealing
<input type="checkbox"/>	Gummed tape with water application
<input type="checkbox"/>	Hot melt sealing
<input type="checkbox"/>	Special carton size
<input type="checkbox"/>	Others such as random size handling

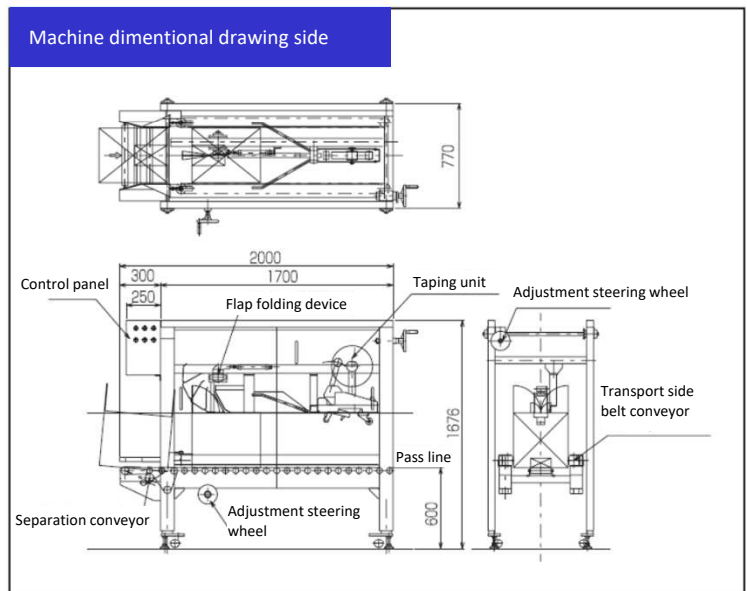

1-19-7, Yokoe, Ibaraki-shi, Osaka, Japan 567-0865

TEL: +81-72-637-3420 FAX: +81-72-637-3464

E-mail: info@yeg.co.jp URL: http://www.yuhara-engineering.com

Business Item ● Cartoning Machine(Horizontal · Vertical) ● Packing Machine ● Carton caser ● Robot caser ● Wrap-around caser
● Case former · Case sealer ● Palletizer ● Auto feeder ● Cost-saving · factory automation facility