

YMH-Series

A single axis interlock horizontal intermittent motion cartoning machine. A series of the processes, carton extraction, loading and sealing are performed in a positive motion.

YMH-101

Intermittent Motion Cartoner corresponding to new generation

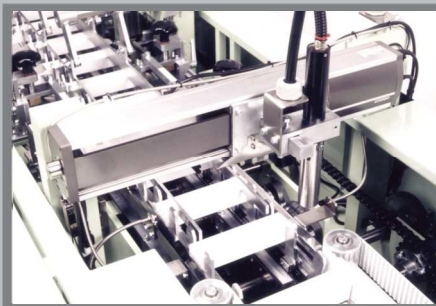
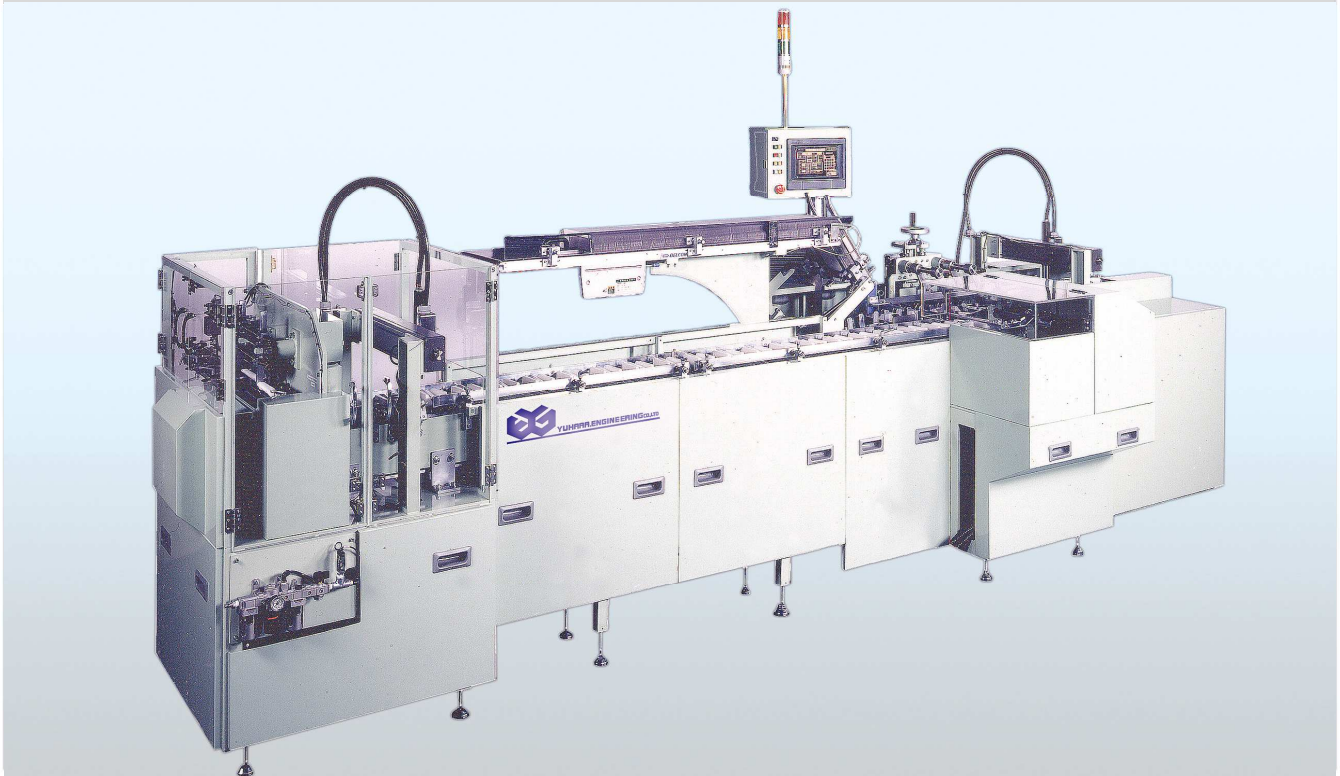

Multifuntionality

It will help design production system with high certainty by setting IJP and various inspection systems and responding flexibly to various options.

High Functionaliy

With an adoption of servo motor in main drive, more certain motion is made possible by optimal control.

Easy size change

Steering wheel adjustment is equipped in the main part to make size change easier and to enhance reproducibility.

※Self-feeding system to bucket conveyor is available as option.

YMH-101

High precision and case erector enhance reliability of production line.

Operation explanation drawing

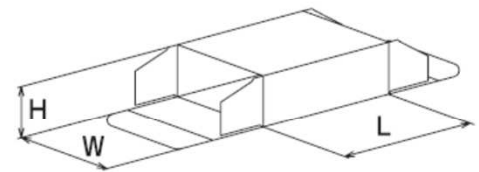
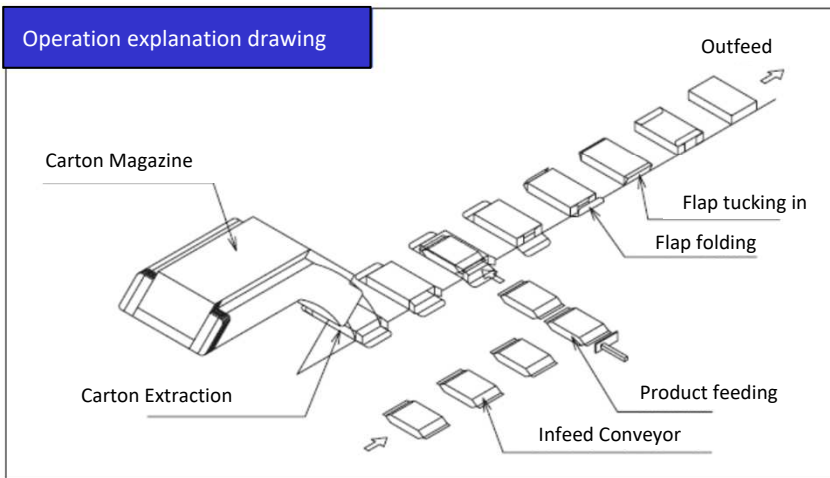

| YMH-101 | | | |
|---------|-----|-----|----|
| | L | W | H |
| min | 80 | 60 | 20 |
| max | 200 | 120 | 60 |

Specification

| | |
|------------------------|---|
| Model | YMH-101 |
| Capacity | 60cpm(MAX70cpm) |
| Electric Power | 3 Phase 200V 3.5kW |
| Compressed Air | 0.49MPa 150Nℓ/min |
| Carton Type | Coated Cardboard (250g-450g/m ²) |
| Carton Extraction Part | 2 step swing system |
| Carton Magazine | Belt conveyor supply (Approx. 1000 pics. accommodation) |
| Product Transport Part | Bucket conveyor |
| Carton Closing Method | 3 flap tuck-in |
| Ejector | Air kicker system |
| Driving Unit | Servo motor |
| Operation Panel | Touch panel |
| Size Change | Steering wheel adjustment and slide adjustment (with digital indicator) |
| Safety Cover | PET full guard cover (with safety switch) |
| Machine Size | L=4200mm W=1390mm H=1500mm |
| Pass Line | 900mm |
| Machine Weight | Approx. 1800kg |

Options

- Product transfer equipment
- 4 Flap hot melt sealing
- Various stamping devices
- Leaflet insert feeder
- Extension of product transfer bucket
- Special carton size
- Various inspection devices

Machine dimensional drawing side

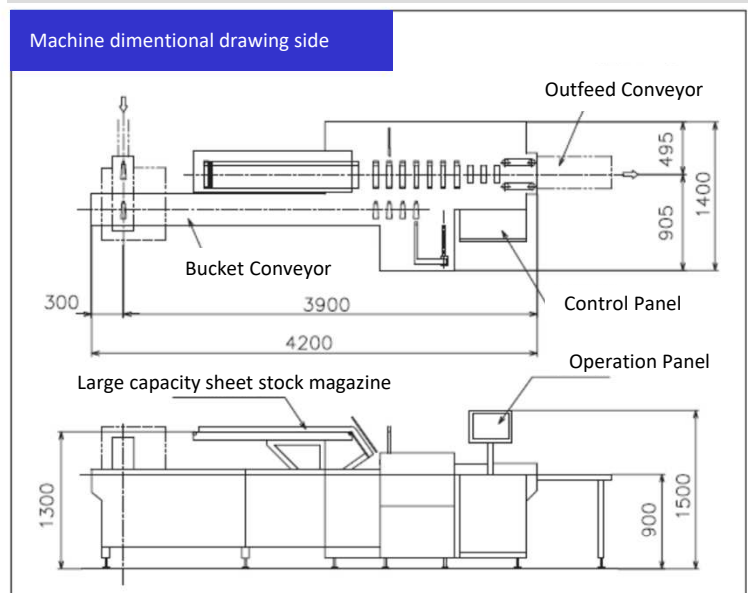

1-19-7, Yokoe, Ibaraki-shi, Osaka, Japan 567-0865

TEL: +81-72-637-3420 FAX: +81-72-637-3464
E-mail: info@yeg.co.jp URL: <http://www.yuhara-engineering.com>

Business Item ● Cartoning Machine(Horizontal · Vertical) ● Packing Machine ● Carton caser ● Robot caser ● Wrap-around caser
● Case former · Case sealer ● Palletizer ● Auto feeder ● Cost-saving · factory automation facility