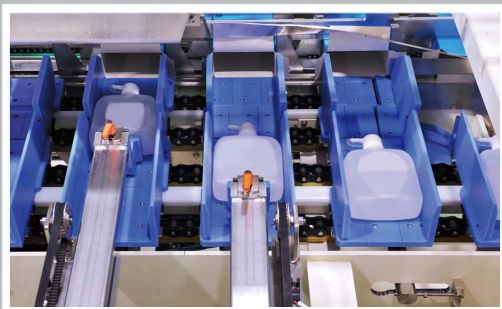
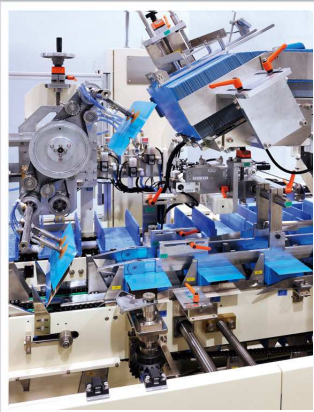
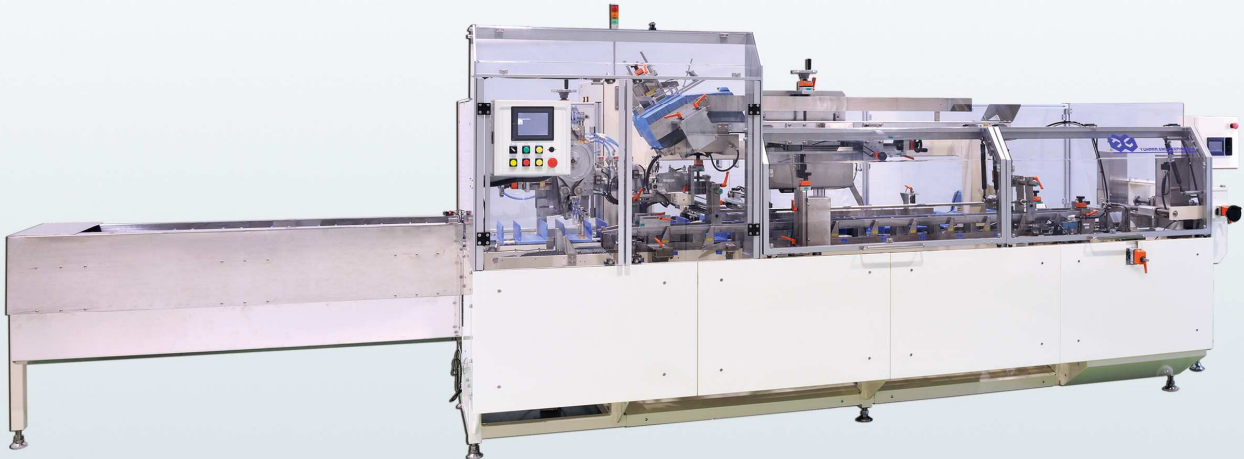

YMH-Series

This is a horizontal continuous motion cartoning machine adopted rotary carton extraction structure. A series of process, carton opening, packing and sealing, is implemented by continuous operation. The under open frame structure improves cleanliness and maintainability.

YMH-102B

Continuous motion cartoning machine corresponding to new generation

**Multifunctionality**

It will help design production system with high certainty by setting IJP and various inspection systems and responding flexibly to various options.

High Functionality

With an adoption of servo motor in main drive, more certain motion is made possible by optimal control.

Easy size change

Steering wheel adjustment is equipped in the main part to make size change easier and to enhance reproducibility.

※Self-feeding system to bucket conveyor is available as option.

YMH-102B

High precision and case erector enhance reliability of production line.

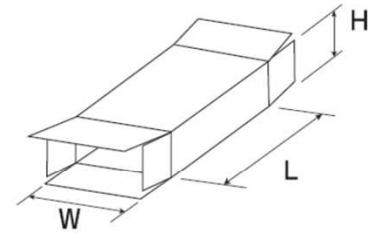
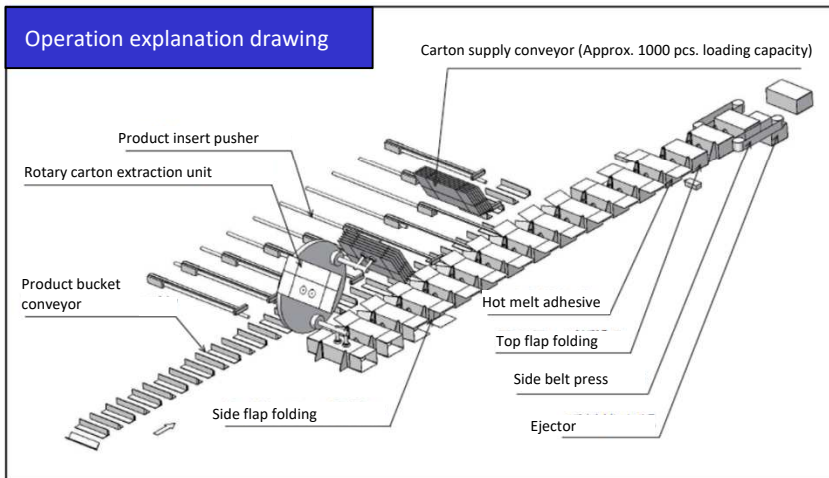

YMH-102B			
	L	W	H
min	95	50	25
max	200	105	40

Specification	
Model	YMH-102B
Capacity	200cpm(MAX240cpm)
Electric Power	3 Phase 200V 8kW
Compressed Air	0.49MPa 150Nℓ/min
Carton Type	Coated Cardboard (250g-450g/m ²)
Carton Forming Part	Rotary structure with 3 heads
Carton Magazine	Belt conveyor supply (Approx. 1000 pieces accommodation)
Product Transport Part	Combination of plunger and cam
Carton Closing Method	Hot melt
Ejector	Air kicker system
Driving Unit	Servo motor
Operation Panel	Touch panel
Size Change	Steering wheel adjustment and slide adjustment (with digital indicator)
Safety Cover	PET full guard cover (with safety switch)
Machine Size	L=5670mm W=1730mm H=1385mm
Pass Line	900 mm
Machine Weight	Approx. 2500kg

Options	
<input type="checkbox"/>	Product transfer equipment
<input type="checkbox"/>	Tuck-in sealing
<input type="checkbox"/>	Various stamping devices
<input type="checkbox"/>	Leaflet insert feeder
<input type="checkbox"/>	Extension of product transfer bucket
<input type="checkbox"/>	Special carton size
<input type="checkbox"/>	Various inspection devices

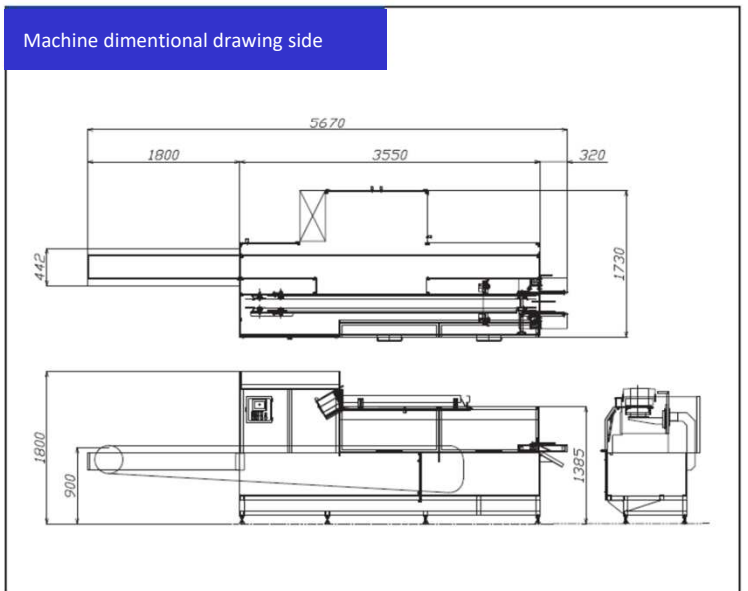

1-19-7, Yokoe, Ibaraki-shi, Osaka, Japan 567-0865

TEL: +81-72-637-3420 FAX: +81-72-637-3464

E-mail: info@yeg.co.jp URL: <http://www.yuhara-engineering.com>

Business Item ● Cartoning Machine(Horizontal · Vertical) ● Packing Machine ● Carton caser ● Robot caser ● Wrap-around caser
● Case former · Case sealer ● Palletizer ● Auto feeder ● Cost-saving · factory automation facility