

YMH-Series

This is a horizontal intermittent motion cartoning machine. A series of process, carton extraction, packing and sealing, is performed in a positive movement. The transparent cover makes it possible to improve visibility and maintainability.

YMH-201 M

Horizontal intermittent motion cartoner corresponding to new generation



Multifunctionality

It will help design production system with high certainty by setting IJP and various inspection systems and responding flexibly to various options.

High Functionality

With an adoption of servo motor in main drive, more certain motion is made possible by optimal control.

Easy size change

Steering wheel adjustment with indicator is equipped in the main part to make size change easier and to enhance reproducibility.

※Self-feeding system to bucket conveyor is available as option.

YMH-201M

High precision and case erector enhance reliability of production line.

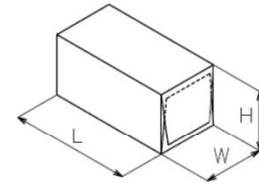
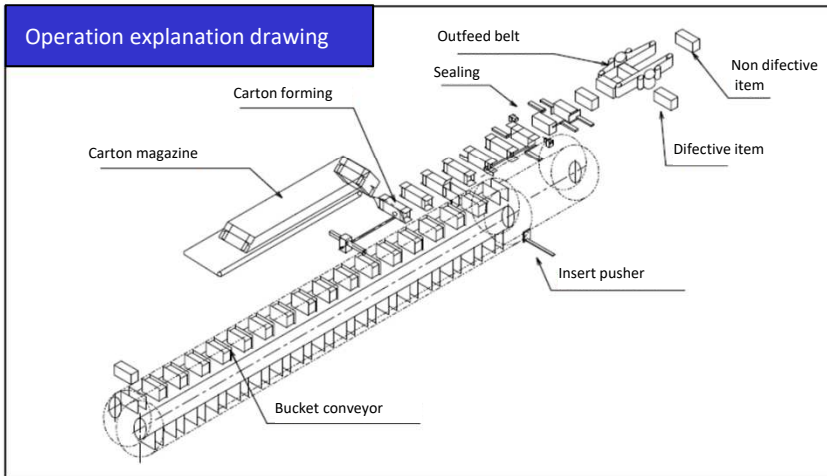

YMH-201M			
	L	W	H
min	170	60	30
max	250	100	90

Specification	
Model	YMH-201M
Capacity	35cpm(MAX40cpm)
Electric Power	3 Phase 200V 7.5kW
Compressed Air	0.49MPa 90Nℓ/min
Carton Type	Coated Cardboard (250g-450g/m ²)
Carton Forming Part	Reciprocating mechanical type
Carton Magazine	Belt conveyor supply (Approx. 800 pieces accommodation)
Product Transport Part	Bucket conveyor
Carton Closing Method	Hot melt (by hot melt applicator)
Ejector	Air kicker system
Driving Unit	Servo motor
Operation Panel	Touch panel
Size Change	Steering wheel adjustment and slide adjustment (with digital indicator)
Safety Cover	PET full guard cover (with safety switch)
Machine Size	L=4340mm W=1506mm H=1570mm
Pass Line	850 mm
Machine Weight	Approx. 2500kg

Options	
<input type="checkbox"/>	Product transfer equipment
<input type="checkbox"/>	Tuck-in sealing
<input type="checkbox"/>	Various stamping devices
<input type="checkbox"/>	Leaflet insert feeder
<input type="checkbox"/>	Extention of product transfer bucket
<input type="checkbox"/>	Special carton size
<input type="checkbox"/>	Various inspection devices
<input type="checkbox"/>	Others

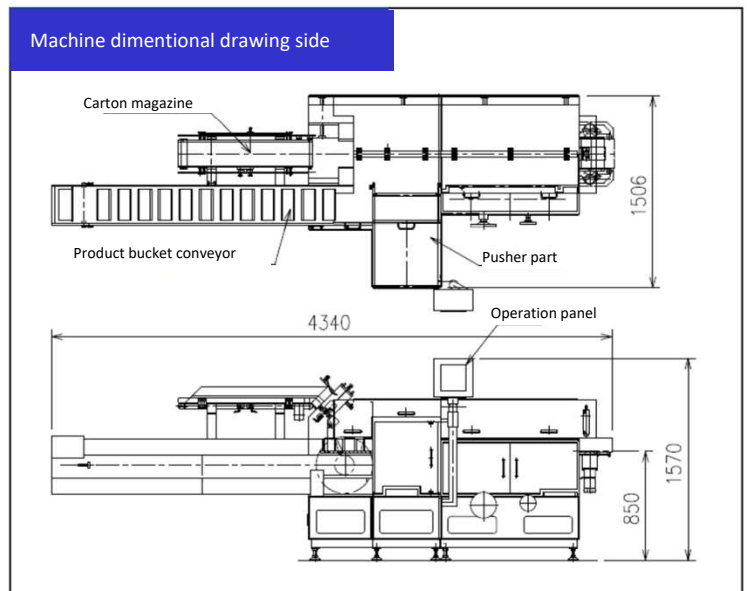

1-19-7, Yokoe, Ibaraki-shi, Osaka, Japan 567-0865

TEL: +81-72-637-3420 FAX: +81-72-637-3464

E-mail: info@yeg.co.jp URL: <http://www.yuhara-engineering.com>

- Business Item ● Cartoning Machine(Horizontal · Vertical) ● Packing Machine ● Carton caser ● Robot caser ● Wrap-around caser
● Case former · Case sealer ● Palletizer ● Auto feeder ● Cost-saving · factory automation facility