

YS-Series

Carton forming process is automated to improve workability. A carton is formed automatically by simply setting sheets on magazine. The semi automatic caser serves as both carton forming and carton sealing so that it is unnecessary to form a carton separately.

YS-002

Semi automatic caser with automatic carton former



Reliability from achievement

Reliability of the taping unit is proven by our achievement.

High Safety

The safety cover is made of PET with safety switch.

Stable supply

Stable supply of cartons facilitates packing process.

Various options

Other various options are available.

YS-002

Simple and high performance enhance productivity of production line.

Operation explanation drawing

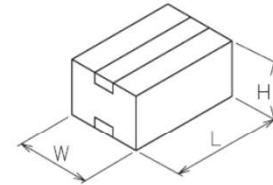
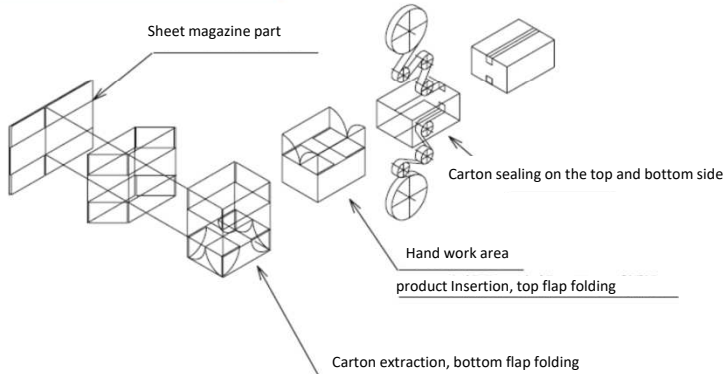

YS-002			
	L	W	H
min	240	180	80
max	500	300	400

Specification

Model	YS-002
Capacity	12cpm(MAX)
Electric Power	3 Phase 200V 500W
Compressed Air	0.49MPa 200Nℓ/min
Carton Type	Carton A type A/F, B/F
Carton forming part on bottom side	Air cylinder drive
Carton magazine	Approx. 60 pcs. accommodation (in the case of A/F)
Carton transport part	Side belt conveyor
Sealing method	Taping unit Kraft or OPP tape
Size change	Steering wheel adjustment and slide adjustment (with digital indicator)
Safety cover	PET full guard cover (with safety switch)
Machine Size	L=2680mm W=1200mm H=1570mm
Pass Line	600 mm
Machine Weight	Approx. 500kg

Options

- Large capacity sheet stock magazine
- Special carton size
- Various stamping devices
- Gummed tape with water application
- Carton right open type
- Others

Machine dimentional drawing side

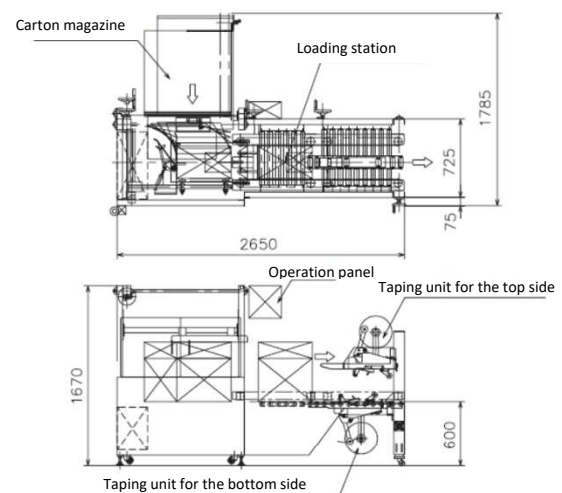

1-19-7, Yokoe, Ibaraki-shi, Osaka, Japan 567-0865

TEL: +81-72-637-3420 FAX: +81-72-637-3464
E-mail: info@yeg.co.jp URL: <http://www.yuhara-engineering.com>

Business Item ● Cartoning Machine(Horizontal · Vertical) ● Packing Machine ● Carton caser ● Robot caser ● Wrap-around caser
● Case former · Case sealer ● Palletizer ● Auto feeder ● Cost-saving · factory automation facility